

TENDER NOTICE NO. 1/2014

SPECIFICATIONS: Category A

Supply of Dining tables and Chairs for hostel mess.

Dining Tables: Made of Stainless Steel of grade :202 SS of Size : length 92" to 96", width 44"to 48", height 30", Frame: four legs made of stainless steel square pipe 1¹/₂". Top of SS sheet of 18 SWG. Frame under the top of 1" sq. pipe with two supports under the top. Drawing as under.

Quantity: 18

Chairs: Dining chairs made of round pipe and round jali seat, back having 5 rod supports. Quote for the both i.e. made of Stainless Steel of grade 202 SS and made of M.S.

Quantity: 200

Rates of above said items should be quoted by weight i.e. "rate Per Kg" only

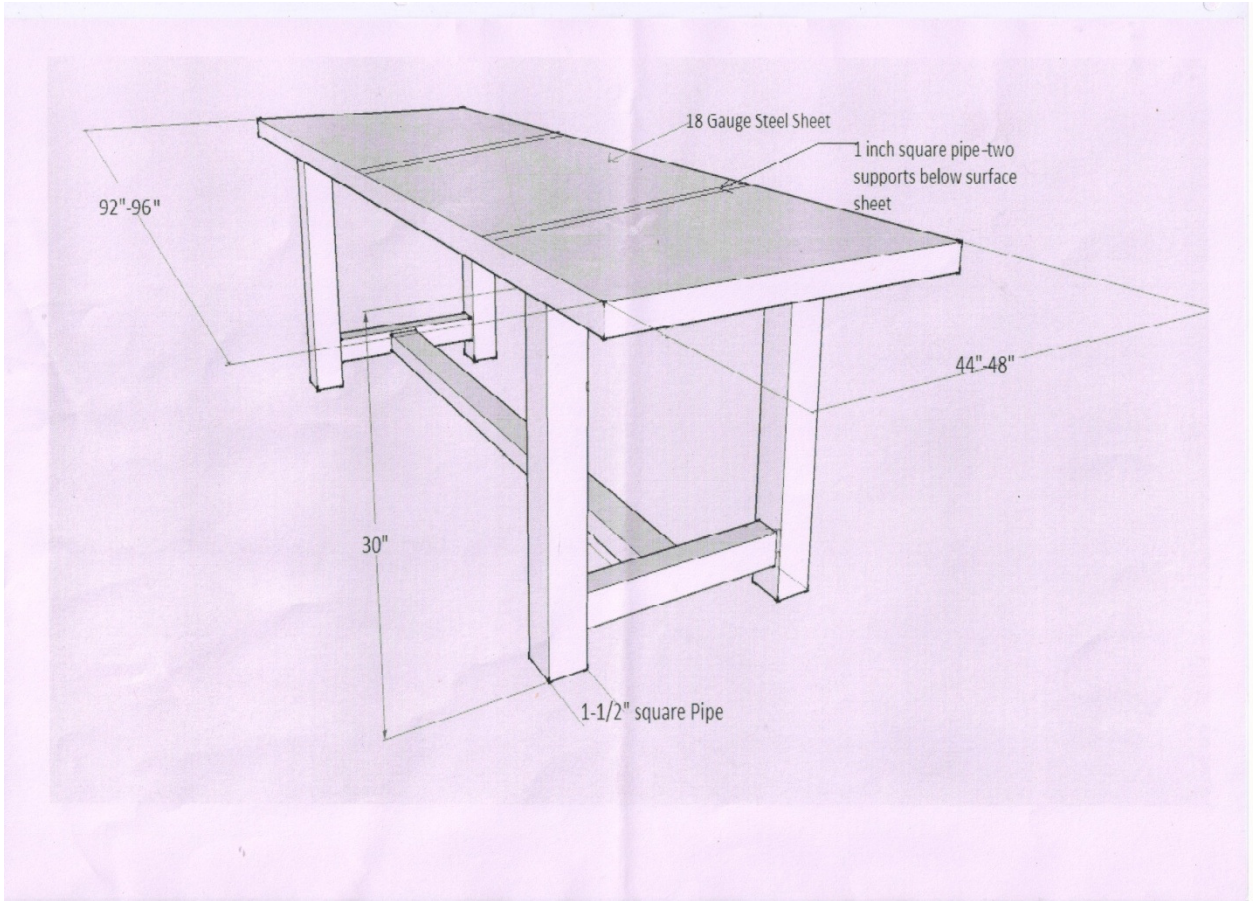

TENDER NOTICE NO. 1/2014

SPECIFICATIONS: Category B

Supply and Fixing of benches in New Block 1st and 2nd Floor step up class rooms for capacity of 900 students (approx.)

FOR SUPPLY AND FITTING OF CLASS ROOM BENCHES

Specifications: Supply and fitting of benches in step up class rooms for capacity of 900 (approx.) students in lecture halls.

1. Size and specifications of class room benches/tables is as per as per Typical details/drawings attached herewith.
2. No. of benches/desks of size 8' complete set=104
3. No. of rear benches of size 8' =12
4. No. of front desks of size 8' =12
5. No. of benches/desks of size 5'10" complete set=208
6. No. of rear benches of size 5'10" =24
7. No. of front desks of size 5'10" =24
8. Quote the rates of Lect. Full bench in running ft (RFT). These rates should include bench bottom, back side, top etc as per the given drawing.
9. Quote the rates of (RFT) of front desk separately.
10. Quote the rates of (RFT) of front desk separately.
11. Quantity may vary as per requirement.
12. After receiving of supply order the supplier has to provide a complete bench/desk set as a sample for pre inspection. The work for manufacturing of ordered items shall be done only after pre inspection and any alteration to be made in shape/fitting by the inspection committee.
13. In case of any doubt of technical specifications supplier can contact the technical committee headed by Dr. R. S. Bhatti.

- 1. Wooden Planks of Imparted Nail wood.
- 2. Steel of (Angles) any standard make like SAIL, Kamohome, Jyoti.

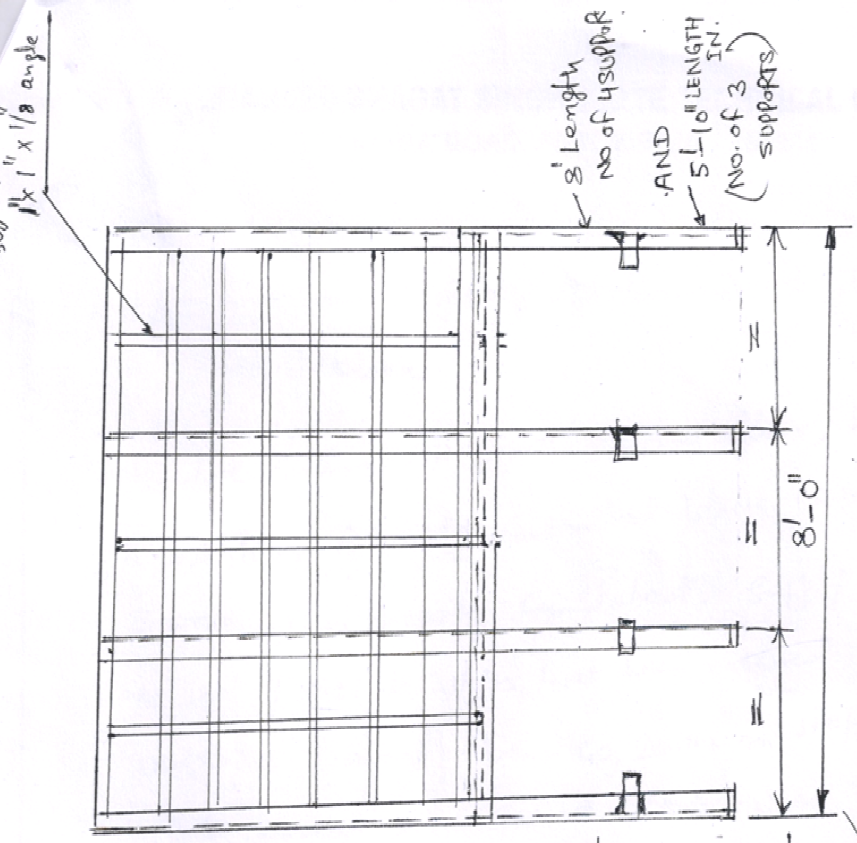

(CLASS ROOM TABLE)

DRN. BY -
CHKD. BY -

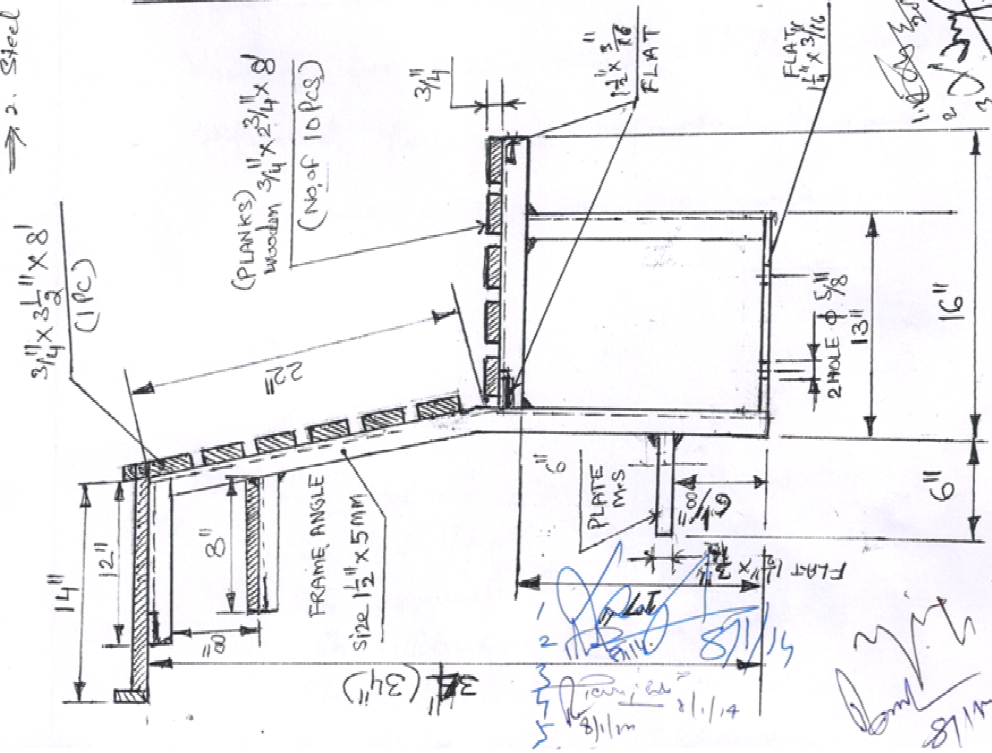

Handwritten signature and date: 11/18

TENDER NOTICE NO. 1/2014

SPECIFICATIONS: Category C

Furnishing of Smart class Room with latest teaching aids

Furnishing of smart class room with False ceiling , fixing of sound absorber sheets (Armstrong) on walls. Air Conditioners Split Type/cassette type 2TR each of LG/Daewoo/O General/Blue Star. Sound System of Sony/Ahuja/Philips make and projection systems etc. and fixing of Projectors.

At present there is one lecture hall to be furnished. Interested bidders are advised to visit the site before submission of tender bid for complete solution

TENDER NOTICE NO. 1/2014

SPECIFICATIONS: Category D

Supply of Electric Cable 3.5 core, 95 mm, 630 mtrs.

Armored Aluminum Conductor, Make: Havells/Plaza/Polycab

TENDER NOTICE NO. 1/2014

SPECIFICATIONS: Category E

Supply of Deep Freezers

Deep Freezer of 72"x28"x36" as per sample in the college hostel, body stainless Steel of SS 304 grade & SS 202 grade (quote for the both) having three upper houses and two front houses of "Jisti" sheet , fitted with Emerson/kirloskar/copland compressor ¾ TR complete in all respect including Voltage Stabilizer of copper winding for hostel Mess foods. Should be mounted on the angle iron frame of 6" height . Also quote for using SS 204 stainless steel separately. Quantity can vary as per requirement.

Quantity 05

TENDER NOTICE NO. 1/2014

SPECIFICATIONS: Category F

Supply of batteries for UPS

Purchase of batteries for UPS in lieu of old batteries (buy-back) and installation

12V26/28Ah Amron/Exide make: Quantity – 128

12V/65AH: Quantity - 16

Pl quote separately for each items i.e for new battery, by back cost of old battery, battery stand etc. Attach Authorization letter for current year.

TENDER NOTICE NO. 1/2014

SPECIFICATIONS: Category G

Supply of Sanitary items appr. Rs. 8.7 lac., general maintenance items appr Rs. 1.77 lac.

Quote in separate sealed Envelope for A,B and C

(A)

SN	Name of material	colour/shape/size	qty	Rate	Amount
1	G.I pipe (ravindra/unik B class)	1.5"	130'		
2	G.I pipe (ravindra/unik B class)	1"	300'		
3	PVC pipe (ISI marked)	4"	300'		
4	Wash Basin regular (parryware, Hindustan)	white	18 pc		
5	PVC cistern 10 ltr capacity (Parryware, Hindustan)	white	18 pc		
6	English seat (parryware, Hindustan)	white	6 pc		
7	Orissan pan (parryware, Hindustan)	white	12 pc		
8	English seat cover (parryware, Hindustan)	white	6 pc		
9	urinal pot regular (Parryware, Hindustan)	white	18 pc		
10	shower (Parryware, Hindustan)	regular	24 pc		
11	Pillar cock CP (Parryware, Hindustan)	regular	18 pc		
12	CP Bib cock long nose (Parryware, Hindustan)	regular	72 pc		
13	Float valve CP (Parryware, Hindustan)	regular	4 pc		
14	Gate Valve (Ravindra/Unik) B class	1.5"	2 pc		

15	Gate Valve (Ravindra/Unik) B class	1"	4 pc		
16	English Seat Jet (Parryware, Hindustan)	regular	6 pc		
17	Stop Cock CP (Ravindra/Unik)	regualr	60 pc		
18	PVC urinal tank (Parryware, Hindustan)	regular	6 pc		
19	Flow trap PVC 4" (Parryware, Hindustan)		20 pc		
20	P-trap PVC (Parryware, Hindustan)		20 pc		
21	S-trap PVC (Parryware, Hindustan)		20 pc		
22	Elbow (Ravindra/Unik)	1.5"	20 pc		
23	Tee (Ravindra/Unik)	1.5"	10 pc		
24	Socket (Ravindra/Unik)	1.5"	10 pc		
25	Union (Ravindra/Unik)	1.5"	10 pc		
26	Elbow (Ravindra/Unik)	1"	30 pc		
27	Tee (Ravindra/Unik)	1"	25 pc		
28	Socket (Ravindra/Unik)	1"	20 pc		
29	Union (Ravindra/Unik)	1"	10 pc		
30	Tanki Nipple	1.5"	2 pc		
31	Tanki Nipple	1"	2 pc		
32	Elbow PVC (Ravindra/Unik)	4"	20 pc		
33	Socket PVC (Ravindra/Unik)	4"	20 PC		
34	Tee PVC (Ravindra/Unikt)	4"	18 pc		
35	Nipple PVC	1.5"x9"	10 pc		
36	Nipple PVC	1.5"x6"	20 pc		
37	Nipple PVC	1.5"x3"	45 pc		
38	Nipple PVC	1"x9"	30 pc		
39	Nipple PVC	1"x6"	25 pc		
40	Nipple PVC	1"x3"	25 pc		
41	Floor Tiles 2'x2' (including labour)	white/regular	3500 sq ft		
42	wall tiles 18"x12" (including labour)	white/regular	2500 sq ft		

(B)

Name of Material	Qty		
Tube fittings 4' ISI	100 pc		
Multi meter (ampere/volt/frequency) ISI	50 pc		
Current transformer 100/5 amp ISI	150 pc		
Bus bar 1.5"x8mm	100'		
Steel wire 5 mm	100'		
Tube holder	100 pc		
CFL 18 watt ISI	50 pc		
Drill Machine (Hammer Type) ISI	1 pc		

Name of Material	Qty	Rate	Amount
PVC Pipe 1" 20' each	6 length		
Socket 1"	10		
Non Returning Valve NRV 3"	PVC=1 CI=1		
PVC Tubler pipe 3"	20'		
Spindle heavy	100	quote by wt	
Ball cock 1" Brass heavy	20	Quote by wt.	
PVC Pipe 1.25" ISI Prince/finolex	20		
T 1.25" Prince	20		
(C)			

SN	Name of Material	Qty	Approx. cost	amount
1.	Wooden length 2"x2"x10' Kail wood	20 pc		
2.	Wooden length 1"x2"x10' Kail wood	15 pc		
3.	Nails 2"x12 no	5 kg		
4.	Nails 3"x12 no	5 kg		
5.	Nails 4"x8 no	5 kg		
6.	Nails 1.5"x14 no	5 kg		
7.	Nails 1"x14 no	5 kg		
8.	Fevicol 1 kg	15 pc		
9.	Ply board 8'x4' 19 mm ISI BWR	10 pc		
10.	ply 8'x4' 12 mm ISI BWR	10 pc		
11.	Machine nut bolt	20 pkt		
12.	Drill bit 6 mm JK	5 pc		
13.	Triangular file	10 pc		
14.	Round blade for cutter 4"	10 pc		

TENDER NOTICE NO. 1/2014

SPECIFICATIONS: Category H

Quote in separate sealed Envelope for A and B

(A) AMC of Computers and peripherals:

Sr. No.	Description	Deptt	No.	Remarks
1	Wipro i-3-2120 3.3 GHZ Wipro P-IV 3 GHZ	Computer Centre	70 40	Quantity may vary as per requirement
2	Wipro=34 intelcore 2Duo=25	CSE Deptt	59	
3	Computers	Chemical Engg	25	
4	Computers	EED	IBM 30	
5	Computers	ME (CAD)	Wipro 40 IBM	
6	Computers	ECE Think centre	Linovo=47	
7	Servers	CSE	IBM X3400=01	

(B) Campuswide Networking and Wi-Fi

01 Complete Project

L2 (DLink DES 3628): Quantity – 03

L2 (DLink DES 3226S): Quantity – 19

L2 (DLink DES 1024R): Quantity – 02

L2 (DLink DES 1210-28): Quantity – 10

L2 (DLink DES 1228 P): Quantity – 04

L3 (DLink DGS 3612 G): Quantity – 02

CISCO – 2900 Router: Quantity – 01

CISCO N series A.Ps: Quantity – 70

DLink 3200 series A.Ps

Terms and conditions:

1. All the parts of said equipments are included in the AMC and it will be the responsibility of the firm/contractor to repair or replace the parts during the AMC period.
2. Payment will be made half yearly. No advance will be paid.
3. The firm/contractor should have atleast 5 years of experience of AMC of reputed institution/firms.
4. The firm/contractor has to provide Resident Engineer.
5. Separate quotes are required for AMC of Campuswide Networking and AMC of Computer Systems & Peripherals.
6. This is the tentative requirement which can be increased/decreased at the time of contract and also the payment will be made as per actual.
7. Payment as per college rules after satisfactory inspection and submission of bills in triplicate.
8. Any other breakage/damage during the work at your end will be borne by you.

TENDER NOTICE NO. 1/2014

SPECIFICATIONS: Category I

AMC of 5 KVA UPS

Specifications:

Sr. No.	Description	Deptt	Total
1	AMC of 5KVA UPS make Delta, Luminous, PCS, Pyramid and Uniline etc, 2KVA online UPS	Computer Centre=08 ECE=08 CSE=08 EED=3 CHE=2 CAD=5 Misc=5 CSE=1 Comp. App. Wing=3	40 Quantity may vary as per requirement
2	UPS PCS 10 KVA	Computer Centre	01

Terms and conditions:

1. All the parts of said equipments are included in the AMC and it will be the responsibility of the firm/contractor to repair or replace the parts during the AMC period.
2. Payment will be made half yearly. No advance will be paid.

3. The firm/contractor should have atleast 5 years of experience of AMC of reputed institution/firms.
4. This is the tentative requirement which can be increased/decreased at the time of contract and also the payment will be made as per actual.
5. Batteries are not covered under AMC.
6. Details of UPS would be provided by the Deptt.
7. Payment will be made as per college rules on quarterly basis after verification of Services provided by you against bills submitted in triplicate copy.
8. Any other breakage at the time of servicing/maintenance would be borne by you.

TENDER NOTICE NO. 1/2014

SPECIFICATIONS: Category J

Aluminum Portioning and False Ceiling

- 1 Aluminum Portioning with 16 G section Size 4"x1.75" with Door & laminated ply with 5mm thick plain glass, rubber & beading with fixation on the site in campus, complete in all respect. With hydraulic door closure, locks and keys etc. and using 2.5"x1.5" section in above said work as per requirement and instructions made by the Indentor/Engineer. Total area as per actual measurement of work done.

approx. area =2000 sq. ft.
2. False Ceiling Armstrong Classic LITE RH 95/98-99, size 600x600x15 mm with Armstrong hot dipped galvanized grid, angled tabular edge profile.

approx. area= 5000 sq ft.
3. Vinyal Flooring Mat type, 2 mm thickness vinyl, Flooring mat make Armstrong/Royal Marble/ISI Brand.

approx. area= 4000 sq ft

Quantity may vary as per requirement.

TENDER NOTICE NO. 1/2014

SPECIFICATIONS: Category K

Lab furniture stools and tables etc

Lab Table 8'x4' frame of 6 legs made of MS sq. pipe with supports (jointing legs with each other) from the top and bottom and fixing of top made of hard wood 19mm sample available in CED Lab.

Quantity =2

Lab Stools: Made of 1"sq. pipe 18 SWG frame of three legs with supports (jointing legs with each other) from the top and bottom and fixing of round top made of hard wood (in single pc) 12-13" round of $\frac{3}{4}$ to 1" thickness. Sample available in the college. Quantity= Approx.200 pc

TENDER NOTICE NO. 1/2014

SPECIFICATIONS: Category L

Printing of Souvenir

Specifications for printing of Souvenir-2014

The Technical requirements of Souvenir (Reminiscences=2014) are as follows:--

- a) Size = 9.5 inch X 7 inch.
- b) Total No. of Pages = 100 excluding front cover
- c) No. of pages for students = 60 (6 students profile data on one page)
- d) No. of pages for Messages = 20
- e) No. of pages for Notes = 20
- f) Cover Page (front & back) – 300gsm Royal Art paper (multicolored).
- g) Rest of Pages- 170gsm art paper with Both Sides Printing (multicolored) with a max 6 photographs on a page.
- g) Envelope (cloth pasted / laminated) with address slips.
- i) Total No. of copies: 550